

Planning

Design your pergola around the function really needed. Is it to be only a plant support, or a window shade, for a covered walkway or to provide some weather protection over your deck or patios.

While size and height will affect design and total cost, you could accept that the appropriate style and location of your pergola(s) can add to the value of your property as well as improve your life style.

So you will first need to decide just what you hope to achieve with this structure.

Local Government Approvals

Construction of outdoor works such as a deck, a pergola, garden sheds, fences etc., will probably need approval by your local authority and we recommend that your Local Councils be consulted early, before detailed planning is commenced. Obtain from Council Officers any information about relevant regulations, the number of and detail required on plans, scale of drawings and what permits (e.g. owner-builders permit?) are required before work commences.

Pergolas are usually simple timber post and beam structures which may be free standing or attached to an existing building or perhaps part of a combined deck-pergola structure. A pergola can be used to provide support for climbing plants; to provide shade for an outdoor living area; or summer shade for windows in solar homes, or to provide a protection from sun and rain over your deck, patio, or path using lightweight zincalume, or aluminium roofing or transparent or translucent fibreglass PVC or polycarbonate sheeting.

Timber Selection

Depending on function and design, timber components of a pergola may be exposed to the hazards of in-ground (posts/poles) and weather and for long-term service should be selected on the basis of expected durability under expected service conditions.

For in-ground use, sapwood free pieces from *naturally highly durable* species such as tallowwood, turpentine, ironbarks, cypress etc. or plantation pine preservative treated to hazard level 4 or 5 (H4, H5) should be preferred.

For above-ground use, but exposed to the weather, the choice would be wider and preferences could include those species mentioned above plus sapwood-free naturally durable species such as blackbutt, spotted gum, messmate, kwila/merbau, stringybarks etc PLUS plantation pine preservative treated at least to hazard level 3 (H3).

For above ground use *protected from weather and associated moisture absorption* the choice is much wider and could include some timber species generally regarded as of low *natural* durability. (This situation would apply to the many structural components of *fully covered* pergolas.

Note 1: Your TABMA timber supplier would be able to advise you on availability and selection of timber quality for these special applications.

Note 2: Most of the structural timber sizes sold as preservative treated in NSW (and Queensland) must be clearly identified by a registered brand. Consult your timber supplier about availability, grading and branding.

Timber Section Sizes

The timber sizes to be specified will generally depend on the type and grade of timber selected and considerable variation is possible if the designer chooses.

However, again you should consult your timber supplier about available grades (and species) before final design or specifications are prepared.

Sawn or Dressed

Timber components specified may be "sawn" i.e. a rough off-the-saw finish, rougher-headed (a fine fluted surface) or dressed-all-round (provided sizes fit to Tables 1-6)

Bracing Needs

Where the pergola is attached to a well supported existing structure such as the house or garage, additional bracing may not be required.

However where the pergola is free standing, bracing is required in two directions. Fix knee braces from both front and rear on to beams or rafters. LARGE pergolas may require bracing of intermediate posts. (see diagrams).

Fasteners and Fixing

All fasteners / fixings / nails / bolts etc. used on external structures such as pergolas are at high risk of corrosion and staining and should be selected from non-corroding materials. In most situations hot-dipped galvanised nails, bolts, framing anchors, stirrups etc. are economical and acceptable.

Exterior Timber Finishes

All timber exposed to weather (sun, rain, dew) will undergo colour change and some surface checking (fine cracking) and erosion of the surface. The effects of weathering can be minimised by timber selection and by coating exposed components with suitable water repellent solutions and or exterior quality stains, or exterior quality paints, used to manufacturers recommendations and maintained as deterioration is observed.

▼ STEP BY STEP ▼

- 1 Draw Plans** Collect information, estimate sizes, check availability of materials, draw up specification, plans obtain building approval and necessary permits.
- 2 Order Timber and Materials** Discuss needs with timber and hardware supplier, place order, check delivery.
- 3 Prepare Site** Locate position of posts, using string line level and measuring tape and prepare appropriate footings for posts - blob footings, posts holes, slab footings as required by design, inserting stirrup bases etc. if required. Allow concrete to cure.

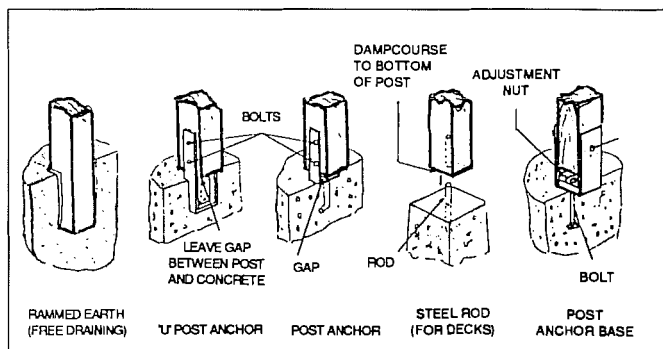

- 4 Cut posts to size**, cut housings for beams if any, prime/seal then locate and erect posts in position, fix temporary bracing, ready for attachment of beams. N.B. Weather exposed joints and connections should not entrap water, prime seal before assembling joints.

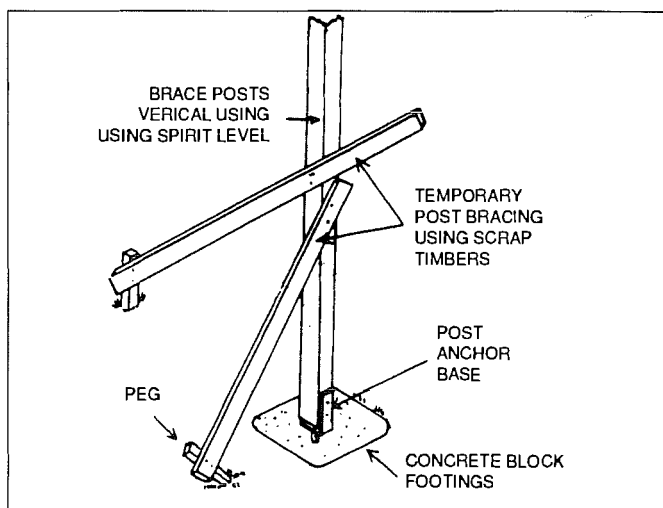

- 5 Attach beams** to posts, using bolts, nails, nail plate connectors as appropriate. Fix ledger -if used- to wall or fascia, fixings to be bolts, coach screws, Loxon bolts etc as appropriate.

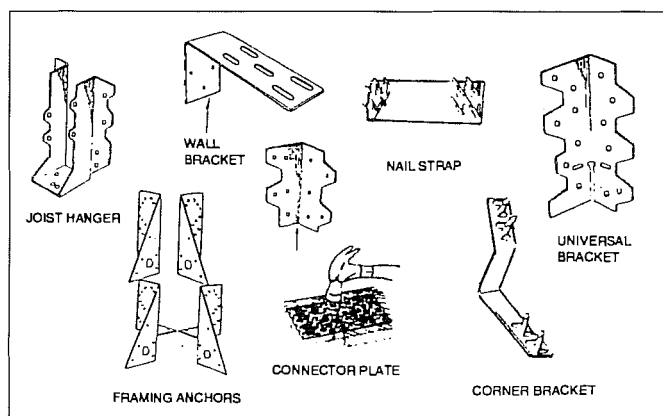

IMPORTANT LIMITATIONS OF DATA IN PROJECT SHEET

1. The timber sizes in Tables 1-6 have been extracted from the NSW Timber Framing Manual which provides data for construction in normal suburban areas where the permissible design gust wind velocity is less than or equal to 41m/s.
2. The sizes given are **MINIMUM** sizes and grades and builders may choose to use larger sizes for aesthetics, or alter some spacings (battens for example) to provide more or less shade, or choose higher (stress) grade material for appearance or economy. Refer to NSW Timber Framing Manual for alternative sizes.
3. The data extracted from the NSW Timber Framing Manual relates to roofed structures in which lightweight or **sheet** roofing would be used. If a roofed or covered pergola is to be built initially, or there is likelihood that at some later date a "shade" pergola will be covered, builders should pay particular attention to those fixings/fastenings which provide 'hold-down' i.e. to resist wind uplift on both structure and roofing materials.
4. Similarly, pergola builders must allow for **bracing** to provide resistance to wind forces which could push the pergola over (i.e. lateral forces). Supporting posts or poles embedded in ground to appropriate depths can provide such bracing but post-in stirrup or the like do not. In the latter case, corner bracing connecting posts to beams and/or posts to rafters should be provided.

As a limited guide to section sizes of the timber components the tables below will indicate a few of the many options available.

Note that the tables give limited data relevant to **SIMPLE** timber pergolas comprising timber posts, beams, rafters, battens but we accept that the alternative constructions could use some of this data e.g. posts could be galvanised steel, or masonry columns; beams could be replaced by ledgers attached to existing walls or fascias etc.

- References for additional information**
- ◆ The National Timber Framing Code AS1684-1992
 - ◆ New South Wales Timber Framing Manual
 - ◆ Roofing Manufactures Data sheets/instructions

- 6 Square up** beam/post and fix corner bracing as required. Trim beam if necessary to length.

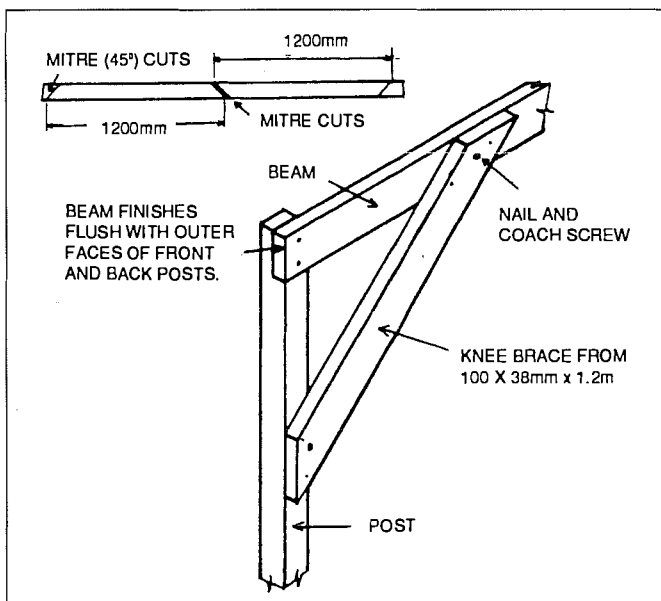

- 7 Attach rafters to beams or ledgers**, skew-nailing with 75mm x 3.75mm galvanised nails, or, particularly for covered pergolas, preferably nailed framing anchors; or if so designed use joist hangers to ledger, fascia or beam.

- 8 Trim rafters to line**, cut and fix corner bracing if required, fix roofing battens if required using two nails per crossover point penetrating at least 35mm into hardwood, 50mm into softwood (preferably twist or ring shank nails into softwoods).

- 9 Fix roofing** to manufacturers specifications if used then add trimwork (e.g. fascias) guttering and downpipe as required. Remove temporary bracing.

- 10 Finish** with water repellents, stains or paints as required.

SOME OTHER OPTIONAL DETAILS

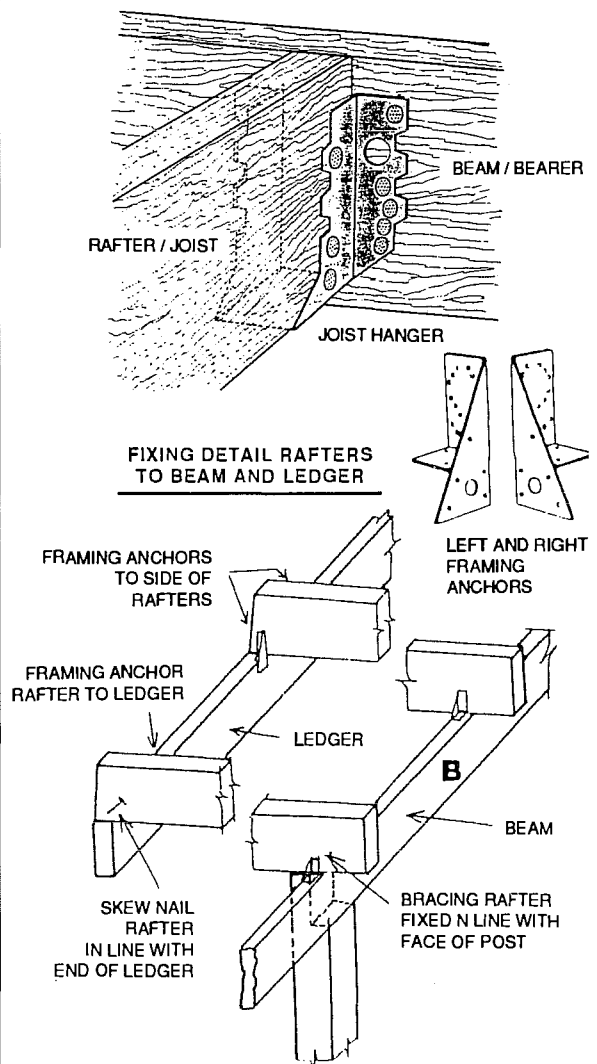

ABBREVIATION CODE USED IN TABLES 1-6

Hardwood F8	Unseasoned native hardwood, minimum structural grade as stress grade F8,
Cypress F4	Unseasoned structural grade cypress pine, minimum stress grade F4.
PT Pine F5	Plantation pine which has been preservative treated, then seasoned and graded to minimum stress grade F5.
Oregon F5	Oregon unseasoned sourced from North America or New Zealand, preferably minimum stress grade F5. (Note if stress grade F4 ex NZ is selected, use data for sizes under cypress F4)

Generally, the above would be the lowest structural quality offered and also lowest price of readily available materials.

TABLE 1

TYPICAL PERGOLA POST SIZE (HEIGHT TO 2.4 M (1))

Hardwood F8	100mm x 100mm Nominal
Cypress F4	100mm x 100mm Nominal
PT Pine F5	90mm x 90 finished 125mm diameter round
Oregon F5	100mm x 100mm Nominal, use only if above ground and protected from water/moisture absorption.

Note: (1) Larger sizes of posts may be necessary if pergola height is greater than 2.7m or where very wide post spacing is desired i.e. posts supporting or restraining large roof areas.

(2) For in-ground posts, add extra 750mm to length for embedment. Choose products suitable for in-ground use.

TABLE 2

TYPICAL PERGOLA SINGLE SPAN BEAM SIZE (3) (depth x width - mm)

N.B. Assume lightweight roofing

TIMBER	RAFTER SPAN					
	to 1.8m		to 2.7m		to 3.6m	
	Beam Span (1)		Beam Span (1)		Beam Span (1)	
	2.7m	to 3.6m	to 2.7m	to 3.6m	to 2.7m	to 3.6m
Hardwood F8	150x50	200x75	175x50	225x75	200x50	250x75
Cypress F4	175x50	225x75	225x50	250x75	200x75	275x75
PT Pine F5	170x45	170x70	220x45	240x70	240x45	240x70
Oregon F5 (2)	175x50	200x75	200x50	225x75	225x50	250x75

Note: (1) Beam Span approximates post spacing.

(2) Use Oregon only if protected from weather and associated moisture/water absorption.

(3) Source: NSW Timber Framing Manual Table 52 for Verandah Plates: single span.

TABLE 3

TYPICAL PERGOLA CONTINUOUS SPAN BEAM SIZE (3) (4) (depth x width - mm)

N.B. Assume lightweight roofing

TIMBER	RAFTER SPAN					
	to 1.8m		to 2.7m		to 3.6m	
	Beam Span (1)		Beam Span (1)		Beam Span (1)	
	2.7m	to 3.6m	to 2.7m	to 3.6m	to 2.7m	to 3.6m
Hardwood F8	125x50	175x50	175x50	225x50	175x50	200x75
Cypress F4	175x50	225x50	225x50	250x75	250x50	275x75
PT Pine F5	170x45	220x45	220x45	220x70	240x45	240x70
Oregon F5 (2)	175x50	200x50	200x50	225x75	225x50	250x75

Note: (1) Beam Span approximates post spacing.

(2) Use Oregon only if protected from weather and associated moisture/water absorption.

(3) Source: NSW Timber Framing Manual Table 52 for Verandah Plates: continuous span.

(4) Continuous span refers to continuous spanning at least two spaces or over at least three post supports

TABLE 4

TYPICAL PERGOLA RAFTER SIZE SINGLE SPAN (1) (2) (depth x width - mm)

N.B. Assume lightweight roofing

TIMBER	RAFTER SPAN (2)					
	to 1.8m		to 2.7m		to 3.6m	
	Rafter Spacing (3)		Rafter Spacing (3)		Rafter Spacing (3)	
	900mm	1200mm	900mm	1200mm	900mm	1200mm
Hardwood F8	100x38	100x38	125x38	125x38	150x38	150x50
Cypress F4	125x50	125x50	125x50	150x38	175x38	175x50
PT Pine F5 (4)	120x35	120x35	120x45	120x45	140x45	170x45
Oregon F5 (4)	100x38	125x38	125x50	125x50	150x50	175x50

Note: (1) Span equals spacing between beams.

(2) Source: NSW Timber Framing Manual.

(3) Rafter spacing to be selected to fit with recommendations of lightweight roofing manufacturer and size of supporting roofing battens if required.

(4) Use Oregon or untreated pine only if protected from weather and associated moisture/water absorption e.g. covered by lightweight roofing.

(5) **Overhang.** Rafter sizes given will permit overhang of at least 250mm. For specific overhang **limits** refer to NSW Timber Framing Manual

TABLE 5

TYPICAL PERGOLA RAFTER SIZE CONTINUOUS SPAN (1) (3) (depth x width - mm)

N.B. Assume lightweight roofing

TIMBER	RAFTER SPAN (2)					
	to 1.8m		to 2.7m		to 3.6m	
	Rafter spacing (4)		Rafter spacing (4)		Rafter spacing (4)	
	900mm	1200mm	900mm	1200mm	900mm	1200mm
Hardwood F8	75x50	100x38	100x38	100x50	125x38	125x50
Cypress F4	125x38	125x50	150x38	150x50	150x50	175x50
PT Pine F5 (5)	120x35	120x35	120x35	120x45	140x45	170x35
Oregon F5 (5)	100x50	125x38	125x38	125x50	150x50	175x50

Note: (1) Span equals spacing between beams.

(2) Source: NSW Timber Framing Manual.

(3) Continuous span requires continuous rafter to span at least two spaces or over at least three beams.

(4) Rafter spacing to be selected to fit with recommendations of lightweight roofing manufacturer and size of supporting roofing battens if required.

(5) Use Oregon or untreated pine only if protected from weather and associated moisture/water absorption e.g. covered by lightweight roofing

(6) **Overhang.** Rafter sizes given will permit overhang of at least 250mm. For specific overhang **limits** refer to NSW Timber Framing Manual.

TABLE 6

ROOF BATTENS - SECTION SIZE (1) (depth x width - mm)

N.B. Assume lightweight roofing

TIMBER	BATTEN SPACING (2)					
	600mm		900mm		1200mm	
	Rafters spaced		Rafters spaced		Rafters spaced	
	900mm	1200mm	900mm	1200mm	900mm	1200mm
Hardwood F8	38x50	50x50	50x50	38x75	50x50	125x75
Cypress F4	50x75	50x75	50x75	150x38	50x75	
PT Pine F5 (5)	35x70	70x35(3)	70x35	70x35	70x35	70x35
Oregon F5 (5)	50x50	50x75	50x75	50x75	50x75	50x75

Note: (1) Source: NSW Timber Framing Manual Table 72

(2) Batten spacing must relate to type and quality of lightweight roofing to be attached. Refer roofing manufacturers instructions.

(3) Note that some battens must be fixed "on edge" rather than "on flat".

(4) Oregon and untreated pine may be satisfactory provided battens are protected from weather and associated moisture/water absorption e.g. fully covered by lightweight roofing.

BUILDING PRACTICE IN WEATHER EXPOSED APPLICATIONS

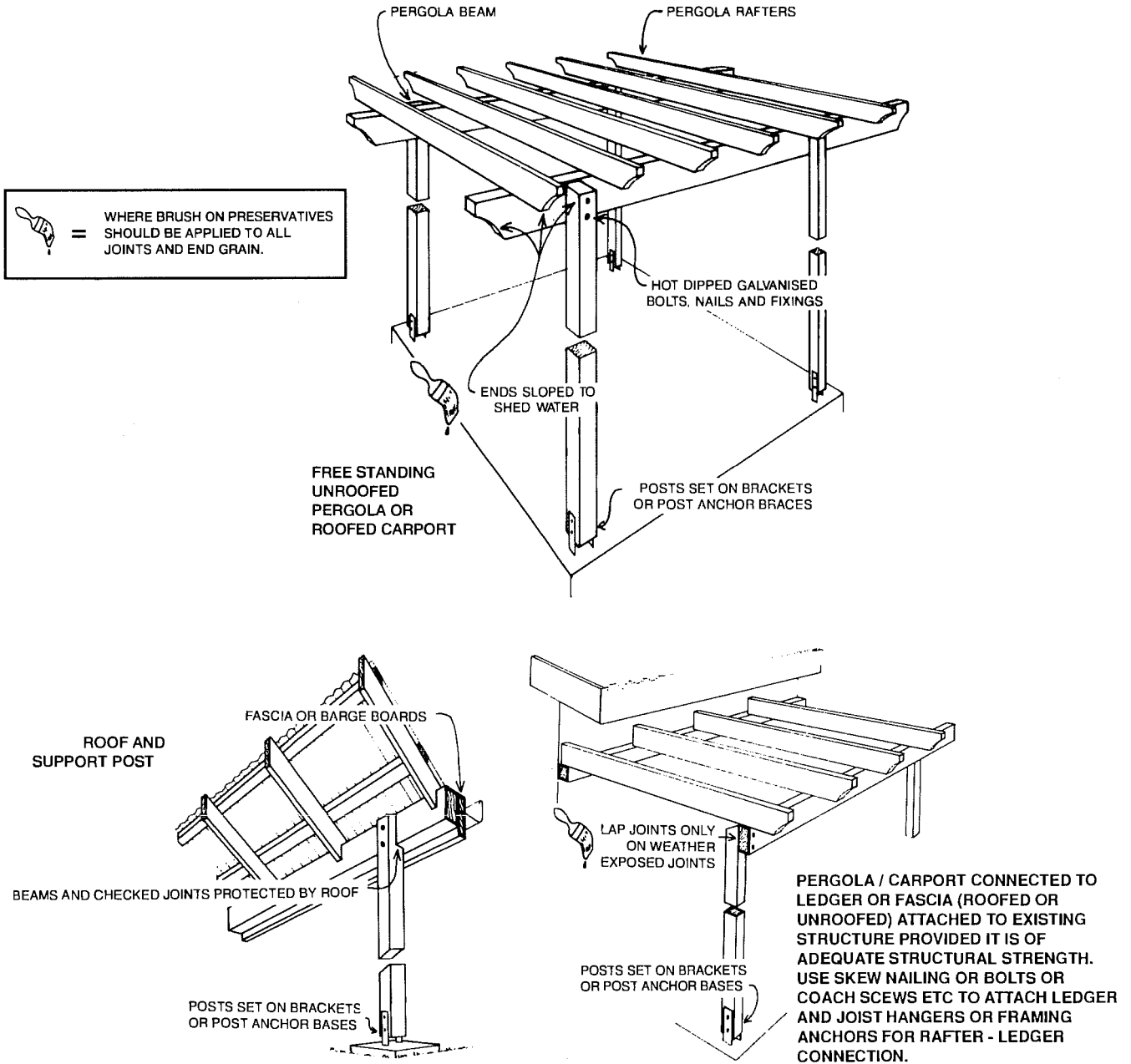

Disclaimer: While the Timber and Building Materials Association (NSW) Limited (**TABMA**) and its members believe this publication is an invaluable guide to this project, the Association cannot guarantee that every statement is without flaw. Therefore, the Association and its members hereby disclaim all liability for errors or omissions of any kind, whether they be negligent or otherwise, or for any loss, damage or other consequence which may arise from any person relying on information stated in this publication.

This brochure was prepared with the assistance and co-operation of the Timber Development Association NSW Ltd.

For further advice telephone the TDA Timber Advisory Service on (02) 360 3088.

Copyright Owner: Timber and Building Materials Association (NSW) Limited

Supplied by